

Meat Tub Washer

Nowicki Meat Tub Washers are designed to save time, water and labor.

Nowicki Meat Tub Washers come with an integrated loading and unloading system for positioning soiled tubs above our washing arm for washing and rinsing of tubs. Our system provides you with automatic control of detergents, water and wash time.

- Designed to save you MONEY
- Stainless steel construction
- Hygienic Design for cleaner tubs
- Reduces back injuries
- Hydraulic system for loading and unloading
- Automatic dosing of chemicals and detergents
- Temperature Control of Water
- Photo eye operator safety system
- Electric, Steam or Combination Systems available
- Closed Water System with Filtration System



Overall Dimension (MWF-1 400)

Length: 1570 mm (2945 mm with installed protective cage)
5.15 ft (9.7 ft with installed protective cage)

Width: 1570 mm
5.15 ft

Height: 1540 mm (2040 mm with installed protective cage)
5.05 ft (6.7 ft with installed protective cage)

Weight: 850 kg - machine without water / 1350 kg - machine ready for work
1874 lbs - machine without water / 2976 lbs - machine ready for work

Corporate Office
2899 Dowd Drive
Santa Rosa, CA 95407
707-523-5940



Blentech
corporation

Sales Office
232 Thurston Lake Dr.
Columbus, MS 39701
662-328-2750

www.blentechprocesssystems.com • www.blentech.com

MWF-1 400 (400 pound Meat Tubs)

Sets and assemblies

The washing machine and its main sets and assemblies are shown on a drawing below:

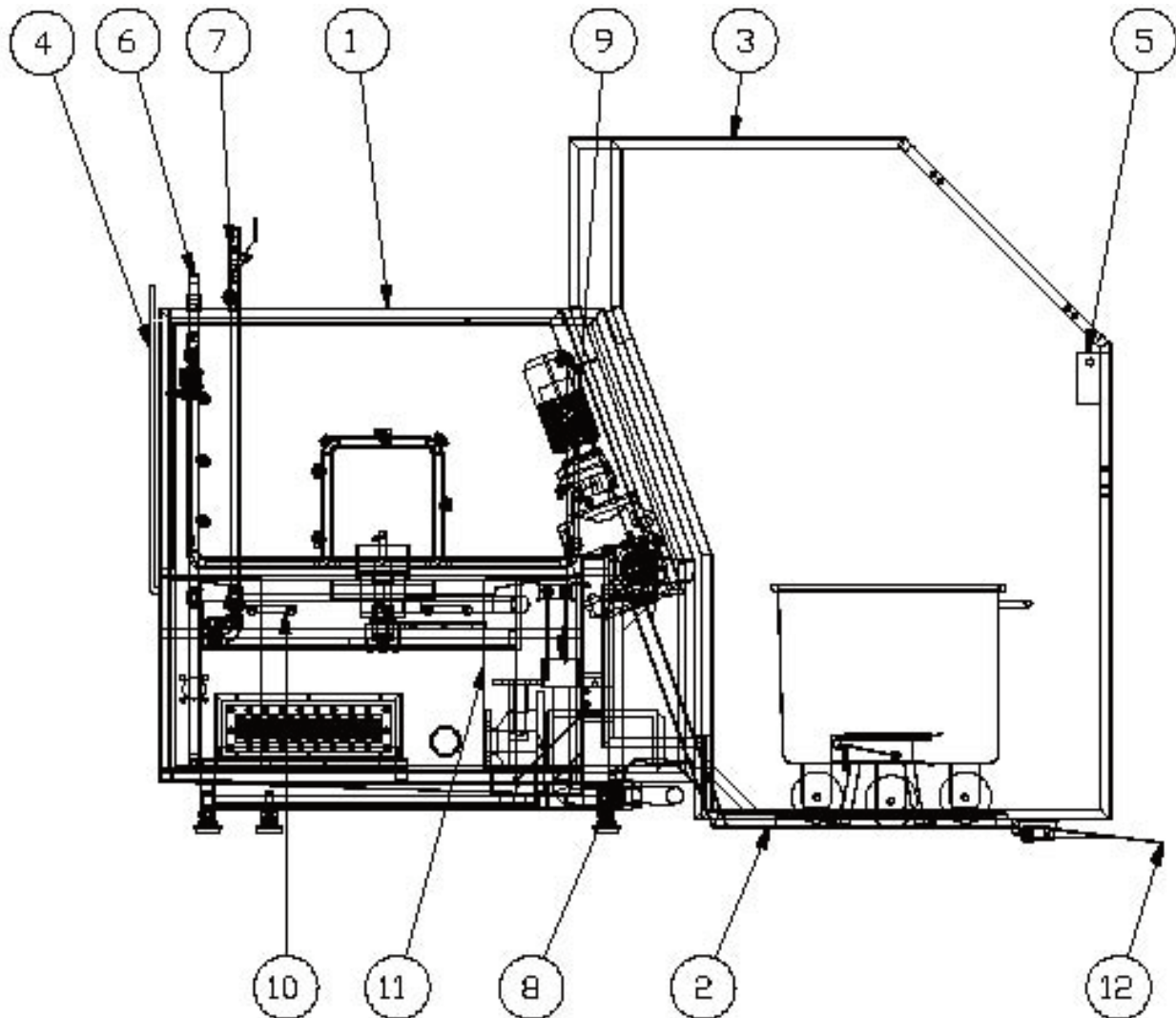

- | | |
|--|---|
| 1. Washing-rinsing chamber | 7. Water connection |
| 2. Rotational shield – system of loading/
unloading | 8. Valve for water release from the main tank |
| 3. Security cage | 9. Overflow |
| 4. Electric connections | 10. Strainers (filter) |
| 5. Operator’s panel | 11. Main water tank |
| 6. steam connection | 12. Carriage for 200ltr meat buggies |

Corporate Office
2899 Dowd Drive
Santa Rosa, CA 95407
707-523-5940



Blentech
corporation

Sales Office
232 Thurston Lake Dr.
Columbus, MS 39701
662-328-2750

www.blentechprocesssystems.com • www.blentech.com