

# BLENTech BRINE MIXERS

Nowicki Brine Mixers are designed to keep a brine solution homogenously mixed.

Our cooling brine mixers prepare, cool and store brine for injection of muscles and meat elements.

All Nowicki Brine Mixers ensure that there are no brine deposits preventing clogged injector needles.



MS-400



- Stainless steel construction
- Two mixing systems
  - Mechanical agitator
  - Injection mixer
- Automatic dosing of fine particle ingredients
- Precise calibration of brine container
- Direct transport of brine to injection
- Fast, thorough mixing of brine solution

**Corporate Office**  
2899 Dowd Drive  
Santa Rosa, CA 95407  
707-523-5940



**Blentech**  
corporation

**Sales Office**  
232 Thurston Lake Dr.  
Columbus, MS 39701  
662-328-2750

[www.blentechprocesssystems.com](http://www.blentechprocesssystems.com) • [www.blentech.com](http://www.blentech.com)

Features	MS-400	MS-1000	MS-1500	MS-400CH	MS-1000CH	MS-1500CH
CONTAINER CAPACITY (Gal/L)	100/400	265/1000	400/1500	100/400	265/1000	400/1500
FULL LOAD AMPS (3/60/480v)	3—4.5	3—4.5	3—4.5	4.5—7.5	4.5—7.5	4.5—7.5
INSTALLED POWER (hp/kW)	2—3/2.1	2—3/2.1	2—3/2.1	3—5/2.5	3—5/2.5	3—5/2.5
COOLING UNIT WITH COMPRESSOR	—	—	—	ZCH 2	ZCH 3	ZCH 4
YIELD OF COOLING (kW)	—	—	—	7.4	16.7	25
POWER OF REFRIGERATION (kW)	—	—	—	3.2	7.2	10.4
LENGTH (in/mm)	55/1390	711/1790	79/2000	67/1700	83/2110	96/2430
WIDTH (in/mm)	48/1220	56/1420	63/1600	45/1150	65/1650	72/1830
HEIGHT (in/mm)	76/1920	83/2100	88/2230	77/1950	88/2230	88/2230
WEIGHT (lbs/kg)	342/155	496/225	992/450	661/300	992/450	1764/800

\* Possibility of using other voltage and frequency

## Assembly of the MS-400CH Brine Mixer:

1. Main tank
2. Loading funnel with cut off valve
3. Set of pump with piping
4. Mixer
5. Unloading valve
6. Cut off valve
7. Cut off valve
8. Cut off valve
9. Pump
10. Electric box with push buttons
11. Cover
12. Glycol installation

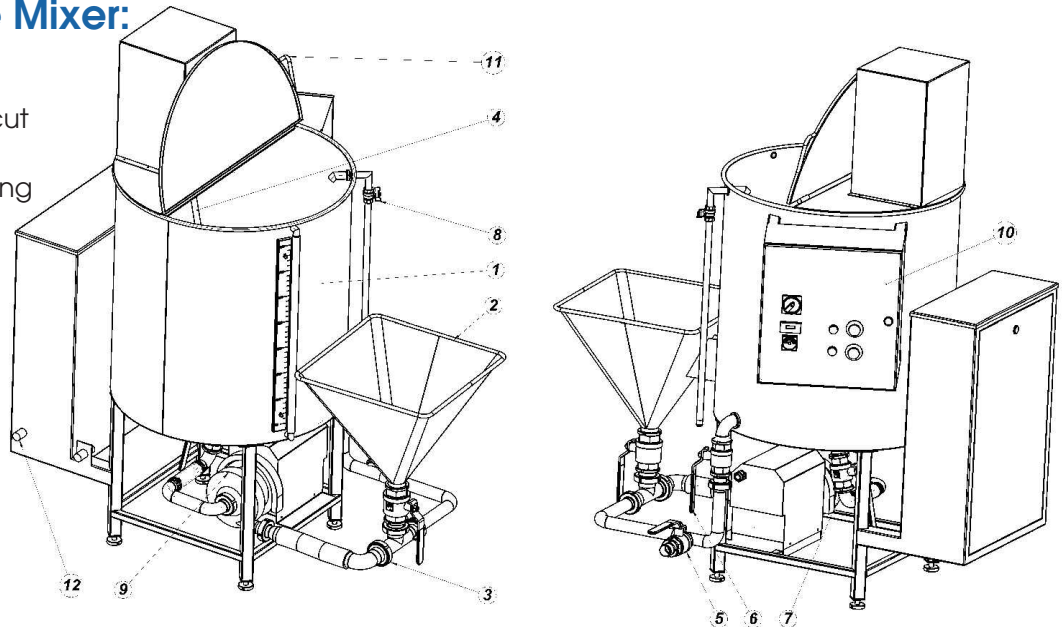

**Corporate Office**  
 2899 Dowd Drive  
 Santa Rosa, CA 95407  
 707-523-5940



**Blentech**  
 corporation

**Sales Office**  
 232 Thurston Lake Dr.  
 Columbus, MS 39701  
 662-328-2750

[www.blentechprocesssystems.com](http://www.blentechprocesssystems.com) • [www.blentech.com](http://www.blentech.com)